

EC-BOS-8

Multi-Protocol Web Building Controller



Overview

The EC-BOS-8 is a compact, embedded controller and server platform for connecting multiple and diverse devices and sub-systems. With Internet connectivity and Webserving capability, the EC-BOS-8 provides integrated control, supervision, data logging, alarming, scheduling and network management. It streams data and graphical displays to a standard Web browser via an Ethernet or wireless LAN, or remotely over the Internet.

The EC-BOS-8 operates with EC-Net™ web-based building management platform powered by the Niagara Framework®.

The EC-BOS-8 can also run EC-Net Access for managing access control systems.

Features & Benefits

- Scalable licensing model and modular hardware make the EC-BOS-8 suitable for installation in small buildings, as well as large multi-unit campuses when combined with EC-Net Supervisor
- Integrates many communication protocols and automation systems including HVAC, lighting, energy, fire & smoke, physical access, video and industrial/processing
- Two on-board isolated RS-485 ports for connecting to various common networks, e.g. BACnet MS/TP, Modbus RTU, Wiegand access control devices
- Option modules for additional physical network connections, e.g. LONWORKS® FTT-10A, RS-232, RS-485, and Wiegand access readers
- USB type A port for station backup and restore functions

Model Selection

To order a fully functional EC-BOS-8, the following three components are required: EC-BOS-8, Core Software, Software Maintenance Agreement (SMA). If ordering a demo core, an SMA is not required. Refer to the [EC-Net Selection Tool](#) to calculate the required components.

EC-BOS-8 Series

Example: EC-BOS-8 with Worldwide WiFi

Series	WiFi Setting ¹
EC-BOS-8: EC-BOS-8 includes two isolated RS485 ports, two 10/100MB Ethernet ports and USB Backup & Restore.	<p>With US WiFi: US WiFi setting for enabling WiFi on EC-BOS-8 units installed in the US.</p> <p>With Worldwide WiFi: Worldwide WiFi setting for enabling WiFi on EC-BOS-8 units installed anywhere in the world except the US.</p> <p>With Permanently Disabled WiFi: WiFi setting for permanently disabling WiFi on EC-BOS-8 units.</p>

¹. Refer to the [EC-BOS-8 Global Shipping Guide](#) for more information.

EC-BOS-8 Core Software

Example: EC-BOS-8 Core - 100 Devices/5000 Points

Series	Devices/Points ¹
EC-BOS-8 Core: EC-BOS-8 core software. Includes standard open drivers. Requires EC-Net 4.1 or higher. Software Maintenance Agreement (SMA) must be purchased in conjunction with core software.	<p>5 Devices/250 Points: Supports up to 5 devices and 250 points.</p> <p>10 Devices/500 Points: Supports up to 10 devices and 500 points.</p> <p>25 Devices/1250 Points: Supports up to 25 devices and 1250 points.</p> <p>100 Devices/5000 Points: Supports up to 100 devices and 5000 points.</p> <p>200 Devices/10000 Points: Supports up to 200 devices and 10000 points.</p>
EC-BOS-8 Core – Demo: EC-BOS-8 core software. Includes all available drivers. Supports up to 500 devices and 25000 points. Runs on EC-Net 4.1 or higher. Note: This license expires annually, and its renewal is covered by the EC-Net Support Fee.	N/A

¹. Devices/Points cannot be added to the Demo version (EC-BOS-8 Core – Demo) of the EC-BOS-8 core software.

For more information regarding the EC-Net drivers currently offered by Distech Controls, refer to the [EC-Net Drivers Reference Guide](#).

EC-BOS-8 Software Maintenance Agreement

Software maintenance is required when purchasing an EC-BOS-8. The minimum initial software maintenance plan is 18 months. Optional 3- or 5-year maintenance may be substituted.

If Maintenance coverage is not purchased for any period, the price of Maintenance for the next period for which it is purchased will be (a) the Maintenance fee for the period(s) for which Maintenance was not purchased, up to a maximum of 5 years; and (b) the Maintenance fee for the next year.

These software maintenance plans are ordered separately according to the EC-BOS-8 model chosen. See the price list for more details. Take advantage of the Asset Manager online tool to receive notifications about SMA expirations and Enterprise SMA to align all SMA expiration dates to a single one for the entire system.

Example: EC-BOS-8 (100 Device Core) 3 year SMA

Series	Software Maintenance Agreement
EC-BOS-8 (5 Device Core)	<p>18 month SMA: Initial 18-month software maintenance agreement. Must be purchased in conjunction with initial core software. Optional 3 or 5 year maintenance may be substituted.</p> <p>1 year SMA: 1-year software maintenance agreement (includes new and interim releases).</p> <p>3 year SMA: 3-year software maintenance agreement (includes new and interim releases).</p> <p>5 year SMA: 5-year software maintenance agreement (includes new and interim releases).</p>
EC-BOS-8 (10 Device Core)	
EC-BOS-8 (25 Device Core)	
EC-BOS-8 (100 Device Core)	
EC-BOS-8 (200 Device Core)	

EC-BOS-8 Device Integration Pack

Example: EC-BOS-8 Device Integration Pack - 25

Series	Devices/Points
EC-BOS-8 Device Integration Pack: EC-BOS-8 device integration pack purchased in <u>conjunction</u> with initial core software.	10: Adds support for additional 10 devices and 500 points to core software. 25: Adds support for additional 25 devices and 1250 points to core software. 50: Adds support for additional 50 devices and 2500 points to core software.

EC-BOS-8 Device Upgrade Pack

Example: EC-BOS-8 Device Upgrade Pack - 25

Series	Devices/Points
EC-BOS-8 Device Upgrade Pack: EC-BOS-8 device upgrade pack purchased any time <u>after</u> initial core software purchase.	10: Adds support for additional 10 devices and 500 points to core software. 25: Adds support for additional 25 devices and 1250 points to core software. 50: Adds support for additional 50 devices and 2500 points to core software.

EC-BOS-8 Software Option

Example: EC-BOS-8 EC-Net Access Pack

Option	Description
EC-BOS-8 EC-Net Access Pack	Enables EC-BOS-8 to run EC-Net Access (minimum 2.4.45/EC-Net 4 4.7.110). Includes licensing for 32 readers.

EC-BOS-8 Hardware Accessory

Example: EC-BOS-8 Wall Plug Module

Accessory	Description
EC-BOS-8 Wall Plug Module	100-240VAC, 50/60 Hz. Wall Adapter – Connects to the 2.5mm barrel plug 24V input on the EC-BOS-8 and includes US, EU, UK, and AU style plugs.
EC-BOS-8 WLAN Antenna Cable Extension	Extension cable and bracket for EC-BOS-8 WLAN antenna.

EC-BOS-8 Add-on Modules

Example: IO-R-16

Add-on Module	Description
EC-NPB8-LON	EC-BOS-8 - Add-on single port LON FTT10A module.
EC-NPB8-2X-485	EC-BOS-8 - Add-on dual port RS-485 module.
EC-NPB8-232	EC-BOS-8 - Add-on single port RS-232 module.
IO-R-16	16 Point IO Module. Powered by IO-R-34. Connected to the EC-BOS-8 remotely over RS485.
IO-R-34	34 Point IO Module. Powered by 24VAC/DC. Capable of powering (4) IO-R-16 modules. Connected to the EC-BOS-8 remotely over RS485.
EC-Net Access Remote Reader	Remote reader module - 2 card reader inputs, 4 supervised inputs, 2 digital inputs, 2 form C (SPDT) relay outputs.
EC-Net Access Remote IO	Remote I/O module - 8 supervised inputs, 2 digital inputs, 8 form C (SPDT) relay outputs.

Expansion Modules

Modules	Description	Maximum Expansion Modules Supported
EC-NPB8-LON	EC-BOS-8 - Add-on single port LON FTT10A module.	4
EC-NPB8-2X-485	EC-BOS-8 - Add-on dual port RS-485 module.	2
EC-NPB8-232	EC-BOS-8 - Add-on single port RS-232 module.	4
IO-R-16	16 Point IO Module	16 ¹
IO-R-34	34 Point IO Module	8 ¹
EC-Net Access Remote Reader	Remote reader module	16 (each or combined)
EC-Net Access Remote IO	Remote I/O module	

1. For detailed information about maximum number of modules supported and maximum combinations, refer to the EC-BOS-8 I/O Modules datasheet.

Maximum Combinations (see figure below):

Expansion 1	Expansion 2	Expansion 3	Expansion 4
EC-NPB8-232 OR EC-NPB8-LON	EC-NPB8-232 OR EC-NPB8-LON	EC-NPB8-232 OR EC-NPB8-LON	EC-NPB8-232 OR EC-NPB8-LON
EC-NPB8-2X-485	EC-NPB8-232 OR EC-NPB8-LON	EC-NPB8-232 OR EC-NPB8-LON	EC-NPB8-232 OR EC-NPB8-LON
EC-NPB8-2X-485	EC-NPB8-2X-485	EC-NPB8-232 OR EC-NPB8-LON	

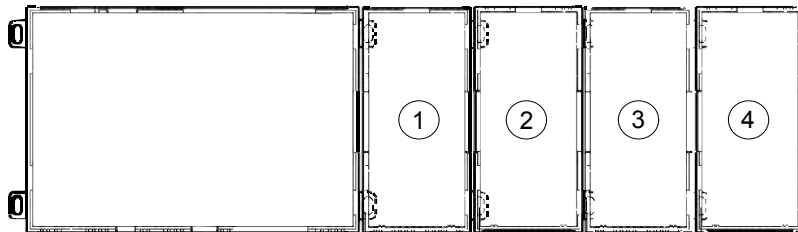

Product Specifications

Platform

Processor	TI AM3352 1000MHz ARM® Cortex™-A8
Memory	1GB DDR3 SDRAM
	- Removable micro-SD card with 4GB flash total storage/2GB user storage
	- Real-time clock
	- Batteryless
	- Secure boot

Communications

Wi-Fi	Client or WAP
Wi-Fi Communication Protocol	IEEE802.11a/b/g/n
	IEEE802.11n HT20 @ 2.4GHz
	IEEE802.11n HT20/HT40 @ 5GHz
Configurable radio	Off, WAP, or Client
Client Authentication Method	WPAPSK/WPA2PSK supported
USB type A connector	Back-up and restore support
RS-485	2 isolated RS-485 with selectable bias and termination
Ethernet	2 10/100MB Ethernet ports
BACnet Listing	BTL, B-BC listed with version 4.4.93 or later

Power Supply

Voltage	24VAC/DC power supply
Consumption	24VA (24VAC); 24W (24VDC)

Environmental

Operating Temperature	-20 to 60°C (-4 to 140 °F)
Storage Temperature	-40 to 85°C (-40 to 185 °F)
Relative Humidity	5% to 95% - Non condensing
Shipping and Vibration	ASTM D4169, Assurance Level II
MTTF	10 years+

Operating Systems

EC-Net 4	4.1 or later
EC-Net Access	2.4.45 or later

EC-Net Access Licensing Quantities

Card Readers	32
Access Rights	250
Schedules	100
Access Zones	50
Simultaneous Users	10
Personnel	20,000
Area Controllers	N/A

Standards and Regulations

UL	UL 916
	C-UL listed to Canadian Standards Associations (CSA) C22.2 No. 205-M1983 "Signal Equipment"
	UL 864, 10 th Edition, UUKL Listed Smoke Control Equipment ¹ (UUKL model only)
CE	EN 61326-1
FCC	Part 15 Subpart B, Class B, Part 15 Subpart C
R&TTE Compliance	1999/5/EC R&TTE Directive
Other compliances	CCC, SRRC, RSS, RoHS

1. For detailed specifications regarding the EC-BOS-8 UUKL model, refer to the Distech Controls UUKL Smoke Control Design Guide (UUKL Design Guide_UG_10_EN) and Distech Controls UUKL Smoke Control Application Guide (UUKL Application Guide_UG_10_EN).

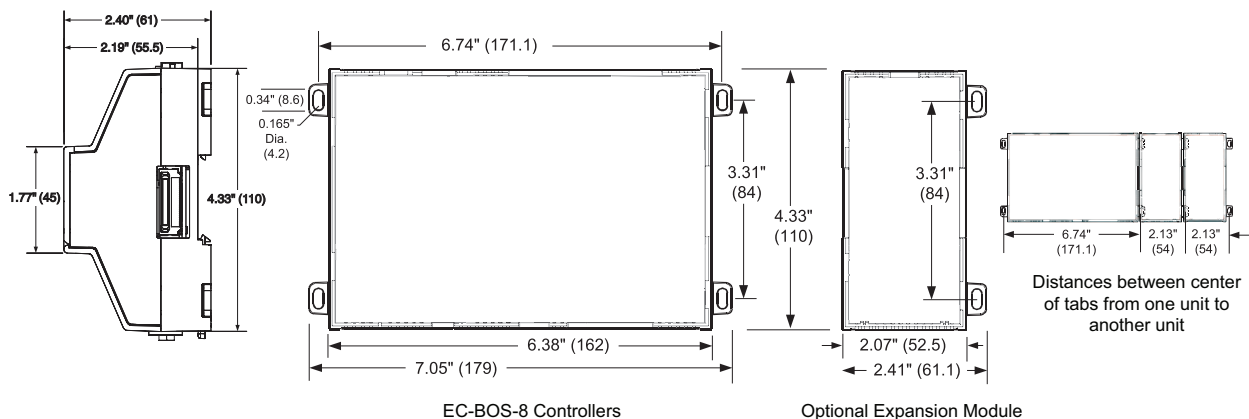

Specifications subject to change without notice.

ECLYPSE, Distech Controls, the Distech Controls logo, EC-Net, Allure, and Allure UNITOUCH are trademarks of Distech Controls Inc. BACnet is a registered trademark of ASHRAE; BTL is a registered trademark of the BACnet Manufacturers Association. The Bluetooth® word mark and logos are registered trademarks owned by Bluetooth SIG, Inc. and any use of such marks is under license. All other trademarks are property of their respective owners.

©, Distech Controls Inc., 2015 - 2021 All rights reserved.

Global Head Office - 4205 place de Java, Brossard, QC, Canada, J4Y 0C4 - EU Head Office - ZAC de Sacuny, 558 avenue Marcel Mérieux, 69530 Brignais, France